

AK 47

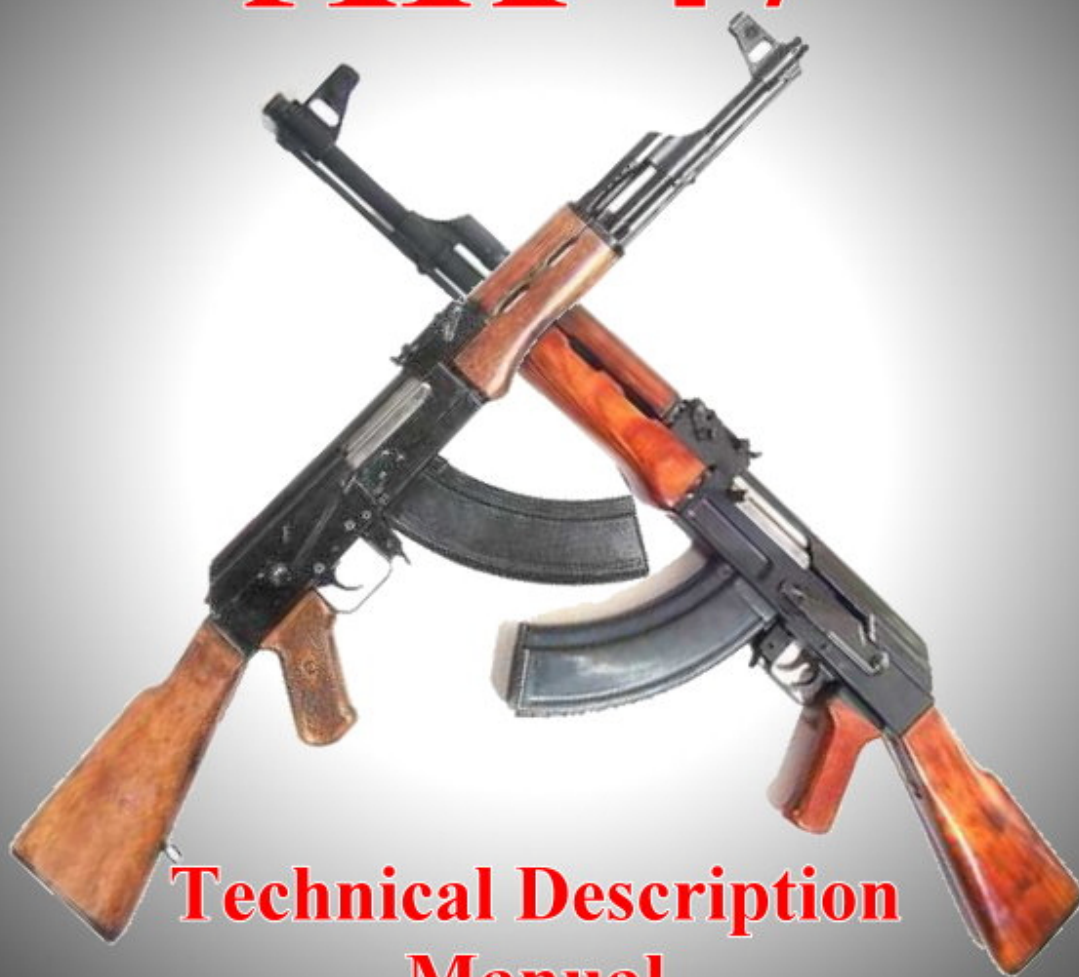

Technical Description Manual

AK - 47

Kalashnikov AK-47 and AKM assault rifles (USSR)



Kalashnikov AK (the original AK-47 with combination stamped / milled receiver)



Modified AK (1955 manufacture), with machined receiver. Note the distinctive machined cuts above and forward of the magazine well.



Automat Kalashnikova Modernized - AKM assault rifle, with the multipurpose bayonet-knife. Note that the stamped receiver has small indents above the magazine instead of the machined cuts on the earlier AK models.



AKMS - AKM with folding buttstock



AKM with GP-25 40mm under barrel grenade launcher

General description:

The original AK was also known as the **AK-47**. It was a gas-operated, selective-fire weapon. Like all 7.62-mm Kalashnikov assault rifles, it fired the Soviet 7.62 x 39-mm M1943 round and used a standard 30-round curved box magazine. The AK came in two versions: one with a fixed wooden stock, and another, the AKS, with a folding metal stock issued primarily to parachutist and armor troops. Except for the differences in the stock and the lack of a tool kit with the AKS, the two versions were identical. The early AKs had no bayonet, but the version with the fixed wooden stock later mounted a detachable knife bayonet.

The improved model, known as the AKM, is easier to produce and operate. It weighs about one kilogram less than the AK. The reduced weight results from using thinner, stamped sheet metal parts rather than machined, forged steel; laminated wood rather than solid wood in the hand guard, forearm, pistol grip, and butt stock; and new lightweight aluminum and plastic magazines. Other improvements include a straighter stock for better control; an improved gas cylinder; a rate-of-fire control alongside the trigger; a rear sight graduated to 1,000 meters rather than 800 meters; and a greatly improved, detachable bayonet.

The AKM also has a folding-stock version, designated AKMS, intended for use by riflemen in armored infantry combat vehicles such as the BMP. Except for its T-shaped, stamped-metal, folding butt stock, the AKMS is identical to the AKM. The folding-stock model can reduce its length from 868 to 699 millimeters. The Kalashnikov assault rifle, also known as the AK-47 (Avtomat Kalashnikova - 47, Kalashnikov automatic rifle, model of 1947), and its derivatives, also known under the common name of AK, is the most prolific small arm of the 2nd half of the XX century. It had been and still is (in more or less modified forms) manufactured in dozens of countries, and used in hundreds of countries and conflicts since its introduction. The total number of the AK-type rifles made worldwide during the last 50 years is estimated at 90+ millions.

By the 1959 the AK was modified again, this time more extensively, and was consequently adopted (after trials) as the AKM (Avtomat Kalashnikova Modernizirovannyj - Kalashnikov Automatic rifle, Modified). The key changes were the introduction of the stamped receiver instead of the milled one, and improved trigger/hammer unit, that introduced a hammer release delay device (often incorrectly referred as a rate reducer). Other changes were the redesigned, slightly raised buttstock and the pistol grip, and the addition of the removable muzzle flip compensator. This spoon-like compensator is screwed onto the muzzle and used the muzzle blast to reduce muzzle climb during the burst fire. The compensator could be replaced by the screw-on "PBS-1 noiseless firing device", generally known as a silencer. This silencer required special, sub-sonic ammunition with heavier bullets to be used. Another change from AK to AKM was a slightly improved rear sight, with settings from 100 to 1000 (instead of the 800 on AK) meters. Both 800 and 1000 meters, however, are excessively optimistic for any practical use, since the effective fire is limited roughly to 300-400 meters, if not less.

Technical description for the AKM assault rifle:

Cartridge:	7.62 x 39 mm	Operation:	gas, selective fire
Locking:	rotating bolt	Feed:	30-round detachable box magazine
Weight:	4.3 kg	Length:	869 mm
Barrel:	414 mm	Rifling:	4 grooves, rh, 1 turn in 235 mm
Sights:	fore, post, adjustable; rear, U-notch, tangent	Muzzle velocity:	710 m/s
Rate of fire:	cyclic, 600 rds/min	Effective range:	400 m

The AKM is a gas operated, selective fire assault rifle. The gas-operated action has a massive bolt carrier with a permanently attached long stroke gas piston. The gas chamber is located above the barrel. The bolt carrier rides on the two rails, machined in the receiver, with the significant clearances between the moving and stationary parts, which allows the gun to operate even when its interior is severely fouled with sand or mud. The rotating bolt has two massive lugs that lock into the receiver. Bolt is so designed that on the unlocking rotation it also makes a primary extraction movement to the fired case. This results in very positive and reliable extraction even with dirty chamber and cases. The rotation of the bolt is ensured by the curved cam track, machined in the bolt carrier, and by the appropriate stud on the bolt itself. The return spring and a spring guide are located behind the gas piston and are partially hidden in its hollow rear part when bolt is in battery. The return spring base also serves as a receiver cover lock. The cocking handle is permanently attached to the bolt carrier (in fact, it forms a single machined steel unit with carrier), and does reciprocate when gun is fired.

The receiver of the AKM is made from the stamped sheet steel, with machined steel inserts riveted into the place where required. Earliest AK-47 receivers were also made from the stamped and machined parts, riveted together, but this soon proved to be unsatisfactory, and most of the AK (pre-1959) rifles were made with completely machined receivers. The receiver cover is a stamped sheet metal part, with stamped strengthening ribs found on the AKM covers.

The relatively simple trigger/hammer mechanism is loosely based on the 1900's period Browning designs (much like the most other modern assault rifles), and features a hammer with two sears - one main, mounted on the trigger extension, and one for the semi-automatic fire, that intercepts the hammer in the cocking position after the shot is fired and until the trigger is released. Additional auto sear is used to release the hammer in full auto mode. The AKM trigger unit also featured a hammer release delay device, which is served to delay the hammer release in the full auto fire by few microseconds. This does not affect the cyclic rate of fire, but allows the bolt group to settle in the forward most position after returning into the battery. The combined safety - fire selector switch of distinctive shape is located on the right side of the receiver. In the "Safe" position (topmost), it locks the bolt group and the trigger, and also served as a dust cover. The middle position is for automatic fire, and the bottom position is for single shots. The safety / fire selector switch is considered by many as the main drawback of the whole AK design, which is not cured in the most of

derivatives until now. It is slow, uncomfortable and sometimes stiff to operate (especially when wearing gloves or mittens), and, when actuated, produces a loud and distinctive click. There is no bolt stop device, and the bolt always goes forward when the last shot from the magazine is fired.

AKM is fed from the 30 rounds, stamped steel magazines of heavy, but robust design. Early AK magazines were of slab-sided design, but the more common AKM magazines featured additional stamped ribs on the sides. Positive magazine catch is located just ahead of the trigger guard and solidly locks the magazine into the place. Insertion and the removal of the magazine requires slight rotation of the magazine around its front top corner, which has a solid locking lug. If available and required, a 40 round box magazines of similar design, or the 75 rounds drums (both from the RPK light machine gun) can be used. Late in production, plastic magazines of the distinctive reddish color were introduced.

AKM rifles were issued with wooden stocks and pistol handles. Late production AKM rifles had a plastic pistol grip instead of wooden one. The wooden buttstock has a steel buttplate with mousetrap cover, which covers the accessory container in the butt. The AK buttstock are more swept-down than the AKM ones. The folding stock version had been developed for the airborne troops and its had an underfolding steel shoulder stock. These modifications of the AK and AKM were designated the AKS and AKMS, respectively. AK were issued with the detachable knife-bayonets, and the AKM introduced a new pattern of the shorter, multipurpose knife-bayonet, which can be used in conjunction with its sheath to form a wire-cutter. All AK and AKM rifles were issued with the canvas carrying slings.

The sights of the AKM consist of the hooded front post and the U-notch open rear. Sights are graduated from 100 to 1000 (800 on AK) meters, with an additional "fixed" battle setting that can be used for all ranges up to 300 meters.

AKM rifles also can be fitted with the 40mm GP-25 grenade launchers, which are mounted under the forend and the barrel. Grenade launchers had its own sights on the left side of the unit.

Capabilities:

All 7.62-mm Kalashnikov assault rifles fire in either semiautomatic or automatic mode and have an effective range of about 300 meters. At full cyclic rate, they can fire about 600 rounds per minute (up to 640 rounds per minute for the AKM), with a practical rate of about 100 rounds per minute fully automatic or 40 rounds per minute semiautomatic. Both the AK and AKM can mount a grenade launcher. Both can have passive image intensifier night sights. Both can function normally after total immersion in mud and water. The fully chromed barrel ensures effective operation even at very low temperatures. The muzzle of either weapon fits into the swiveling firing points of the BMP. Thus, the infantryman can fire the weapon while the vehicle is moving.

Limitations:

The most serious drawback to the AK and AKM is the low muzzle velocity (710 meters per second) of the relatively heavy 7.62-mm round. This results in a looping trajectory that requires a clumsy adjustment for accuracy at ranges beyond 300 meters. The barrel overheats quickly when the weapon fires for extended periods, making the weapon hard to handle and occasionally causing a round to explode prematurely in the chamber. The exposed gas cylinder is easily dented, sometimes causing the weapon to malfunction.

Notable Features

The selector lever is a large lever on the right side, easy to manipulate with mittens under arctic conditions.

The highest position of the selector lever is safe. Safe prevents trigger movement and cocking. In many models, this position is unmarked. International weapons may place a "0" in this position.

The bottom position is single-shot. On Russian weapons this is marked "OD" in Cyrillic. International weapons may have a "1" or a single dot.

The middle position is full automatic. On Russian weapons this is marked with "AB" in Cyrillic, for "ABtomat...". International weapons have an infinity-sign or multiple dots in this position.

Classic AK-series have a cycle rate of 600RPM. Newer versions have delayed automatic sears that cycle at 300RPM.

The standard flip-up iron sight is calibrated with each numeral indicating in hundreds of meters. It is released by squeezing the two buttons on the back end. The standard calibration of the flipped-down sight is 50 meters, the normal minimal distance for aimed fire. Distances below this range are usually handled with instinctive fire. For night fighting, Russian models have a flip-up luminous dot, also calibrated at 50m. The sights are one of the most heavily-criticized feature of the rifle, being both farther from the eye than many common rifle sights, and less accurate than peep-sights, such as those found on the M16 rifles.

The magazine release is in front of the trigger guard. The trigger guard is very large, to permit gloved fingers.

A sling is provided for accurate aimed fire. It should wrap around the left forearm.

Models for paratroop, horse troops and mechanized troops have folding stocks. Most fold sideways, but a few fold forward over the pistol grip to make submachine guns.

Bullpup models exist, in which a shoulder pad is bolted onto the back of the receiver, and the trigger is moved up to the front of the barrel. These weigh less because they have no stock, yet they still have full-length barrels.

Some models include an integral folding bayonet.

Some models include a gas valve on the forward gas port (above the barrel) to permit firing grenades. Sometimes the valve is controlled by flipping a special "grenade sight" up into position.

Some makes of removable bayonets can attach to their scabbards to form a scissors-style barbed-wire cutter.

The barrel and chamber are chromium-plated, to resist corrosion, but cleaning after every firing is recommended. Most military ammunition uses corrosive primers.

A cleaning rod is under the barrel. It bends slightly for removal. In standard AKs, cleaning patches and a metal bottle of oil and solvent are in compartments in the shoulder-pad of the stock.

To field strip, release the magazine catch, remove the magazine, and cock the rifle, holding the left hand ready over the receiver to catch any ejected cartridge. Release the catch on the right side of the rear sight. Push the piston assembly cover forward, detaching it from the rear receiver. Lift it and then pull it backwards. Remove the piston assembly and bolt. Clean as needed, with special attention to the barrel, gas hole and gas piston. Oil slightly and reassemble. Before inserting the magazine, press the trigger to release the spring tension.

Ballistics

The standard AK-47 or AKM fires a 7.62x39mm round with a muzzle velocity of 710 m/s. Muzzle energy is 2,970 joules. Cartridge length is 38.6mm, weight is 18.21g. Projectile weight is 7.91g.

The new model AK-74 fires a 5.45x39mm round with a muzzle velocity of 900 m/s. Muzzle energy is 1,385 joules. The cartridge weight is 10.75g. Projectile weight is 3.42g.

Both bullets are full metal jacket designs. The outer plating is copper and zinc. The shell is steel. There's an inner layer of soft lead, with a core that's a steel penetrator. There is a bubble in the nose.

When shot into 10% ballistic gelatin at 4C, the bullets always tumble. X-ray examinations of ten bullets showed that the lead invariably shifts into the bubble in the nose, possibly unbalancing the bullet.

With the 5.45mm bullet, the tumbling produced a maximum wound expansion twice at 10 and 40cm of depth. With the 7.62mm bullet, the maximum wound expansion occurred at approximately 30 and 40 cm. 40cm is the average thickness of a human trunk.

Some people have said that the Russians were concerned about the lower energies of the assault-rifle bullets and designed them to cause more damage than might otherwise occur.

Rate of fire is between 300 and 600 rounds per minute. Later models have modifications to the trigger assembly and bolt to fire more slowly. This helps to make the weapon more controllable and waste less ammunition. This may help reduce logistic requirements.

DISASSEMBLY

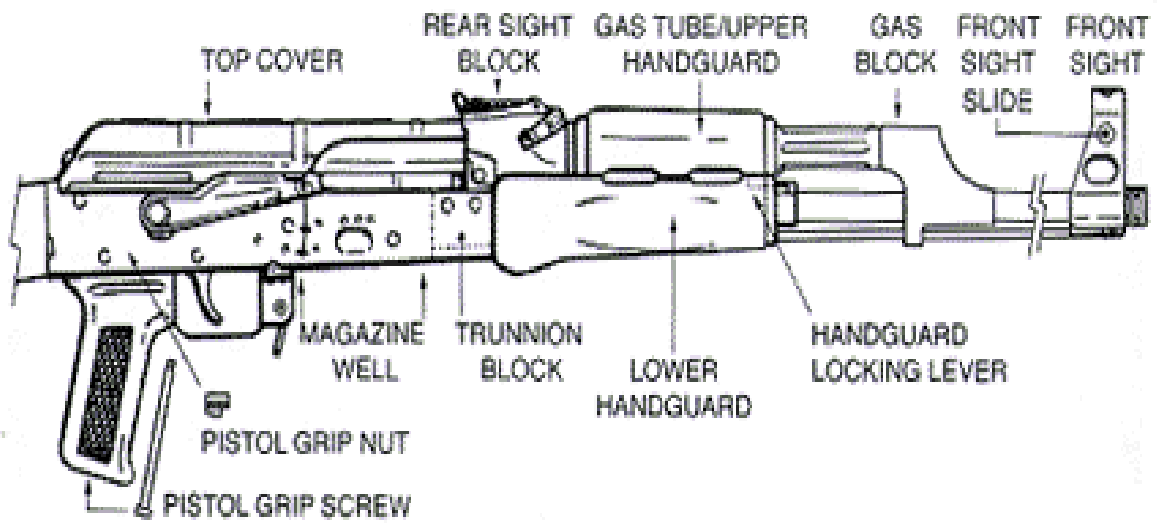

AK-47 Assembly and Disassembly

When doing extensive work on a firearm, work on a soft surface so that it won't scratch the metal parts of the gun. It is also wise to work where light is good and parts will not be lost. In general it is best not to disassemble a firearm any more than is really necessary to clean it or repair or replace a part. Even then it is seldom necessary to disassemble the rifle beyond the field stripping stage. Every time a firearm is disassembled beyond the field stripping stage, it will take some time for some parts to regain their fit, some parts may tend to shake loose and fall out when firing the weapon. Some parts of the AK-47 line are riveted together. Repairing these can be quite a hassle, since the end of the rivet has to be ground off and a new one set after the part is replaced.

Ideally the disassembly steps listed below will **NOT** be carried out by anyone other than a competent gunsmith. A lot of damage can be done if disassembly is done without proper knowledge.

1. Remove the magazine from the gun and cycle the action making sure the firearm is empty.

2. Push in the retaining lever (the little button at the end of the receiver closest to the stock) on the rear of the receiver, then lift the receiver cover off and back to remove it exposing the action.

3. Take out the action spring & retaining rod by pushing them forward to release them, then lift them up slightly and back them out of the receiver.

4. Remove the bolt and bolt carrier (which will also have the gas piston attached to it) By pulling them back and out.

5. Take the bolt out of the carrier by twisting the bolt counterclockwise and pulling it out of the front of the carrier.

6. Remove the gas cylinder by pulling it backward and lifting it out.

7. The extractor and extractor spring are held in place by the large pin (which may be a solid or roll pin depending on the rifle located on the side of the bolt near the locking lugs. Before trying to drift out this pin check to be sure one side isn't staked if it is go out the other side opposite the staked spot in the bolt. Drift the pin out with a drift punch or small nail to free the extractor. Be careful since the spring is under tension.

8. The smaller pin located on the side of the bolt near the locking lugs retain the firing pin (and its spring on models with a firing pin spring) note whether the pin is staked in place. Drifting the pin out frees the firing pin take care since this spring is also under pressure.

9. The gas piston is held to the bolt carrier extension arm by a roll pin. This pin should be should be drifted out only if the piston needs to be repaired or replaced since damage to the piston can occur during this process.

10. Flash hidens or muzzle nuts are sometimes held in place by a pin but usually are screwed onto the barrel some AK's lack them entirely.

11. The gas port block is generally held in place by cross pins don't remove it unless its absolutely necessary, this can be a tedious process on some rifles and it may be hard to replace it so it stays in place.

12. The fore grip may be attached to the rifle in a variety of ways the method for removal is best determined by studying the rifle.

13. The trigger groups pins are released by removing the looped retaining spring on the left inside of the receiver on semi-auto rifles, or the long leg of the disconnector spring on select-fire guns. Before freeing the spring or leg place the selector in the fire position and while restraining the hammer pull the trigger. Hold the hammer and carefully lower it until it is fully forward, facedown. This is done the retaining spring can be pulled forward and out by grasping its loop with a pair of needle nosed pliers and pulling forward and out. On select fire rifles the long leg of the disconnection spring should be pulled up to free the disconnection pin remove the pin out the left side of the receiver and then take out the disconnection and its spring to free the other parts of the trigger group.

14. Once the retaining spring is removed the trigger group is freed by sliding the hammer and trigger pins out the left side of the receiver. This will free the hammer and its spring which can be removed by turning them slightly and lifting them out. Next the trigger and sear can be removed along with the rate reducer and its sear (takes care not to lose the sear spring which sits between the sear and trigger.)

15. If the safety/selector needs to be removed rotate its forward end upward so that it can be pulled out the right side of the receiver.

16. Most stocks are held in place by screws or with many folding stocks pins. Do not remove the stock unless absolutely necessary for repair or replacement.

17. The magazine release and its spring are held in place with a rivet. Do not remove unless absolutely necessary.

18. Pistol grips are generally held in place by a bolt which can be unscrewed through the open base of the grip.

19. The front sight post generally screws into its base. The sight assembly can be removed by drifting a set screw or screws may need to be loosened first. The front sight should not be removed unless absolutely necessary since the tight fit keeps it zeroed.

20. The rear sight is generally pinned or screwed into place with its base welded onto the rifle. Note the leaf springs alignment so that it may be properly realigned.

To reassemble reverse the process.

AK-47 Parts and Diagrams

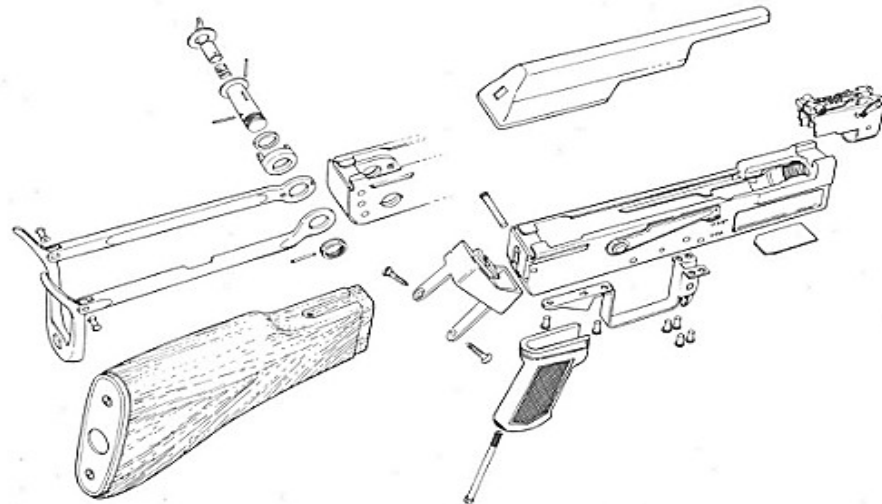

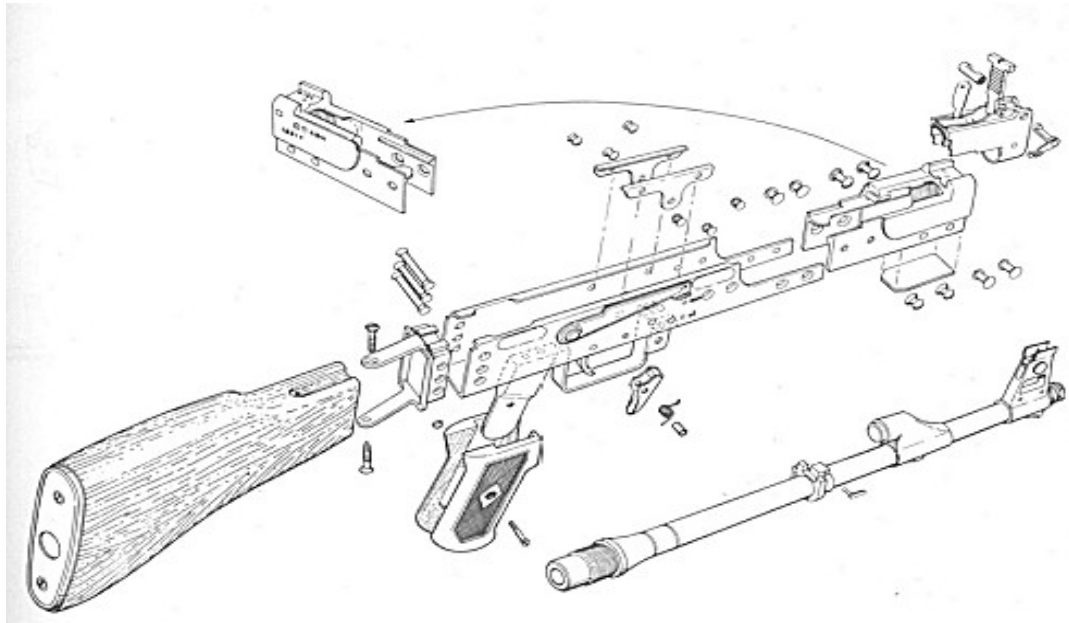

AK-47 Exploded Parts View

- 1** - Barrel with receiver, with rear sight and stock
- 2** - Receiver cover
- 3** - Bayonet
- 4** - Recoil mechanism
- 5** - Bolt Carrier with gas piston
- 6** - Gas tube with upper hand guard
- 7** - Bolt
- 8** - Cleaning Rod
- 9** - Fore end
- 10** - Magazine
- 11** - Combination tool with accessories

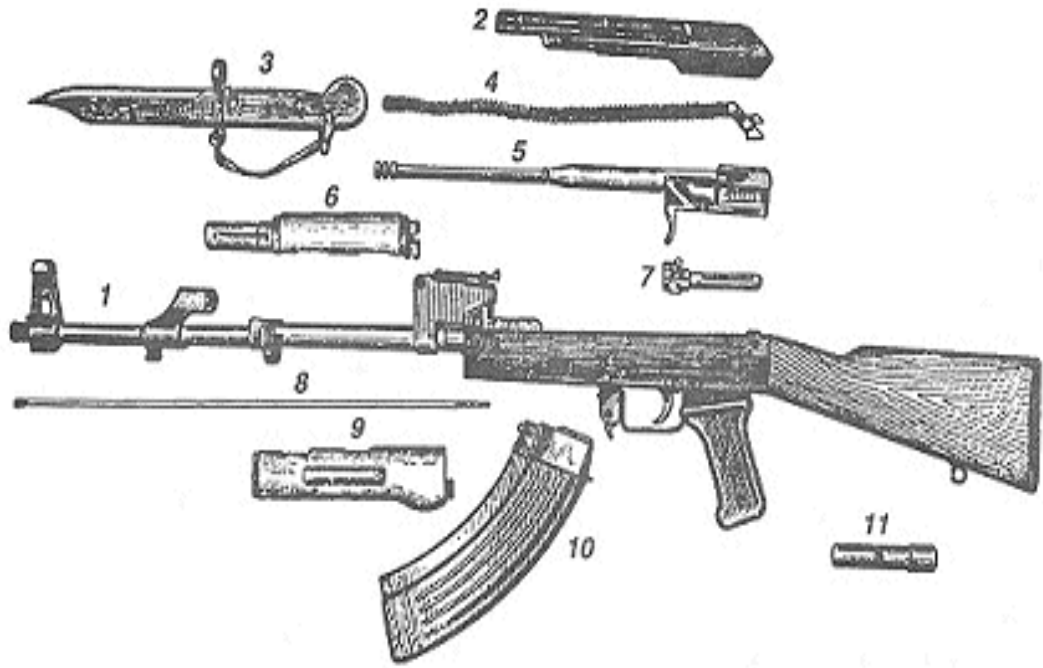

AK-47 Bolt Disassembly

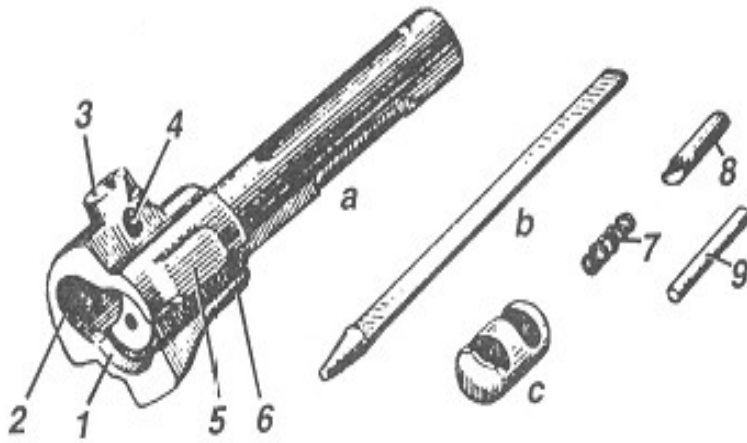

a - Bolt Body

b - Firing pin

c - Extractor

- 1 - Recess for case bottom
- 2 - Extractor slot
- 3 - Guide lug
- 4 - Hole for extractor pin
- 5 - Locking lug
- 6 - Longitudinal slot for ejector lug
- 7 - Extractor spring
- 8 - Extractor pin
- 9 - Firing pin retaining pin

The bolt delivers the cartridge into the chamber, closes the barrel bore, dents the primer, and extracts the case from the chamber. The bolt consists of body, firing pin, extractor with spring and pin, and firing pin retaining pin.

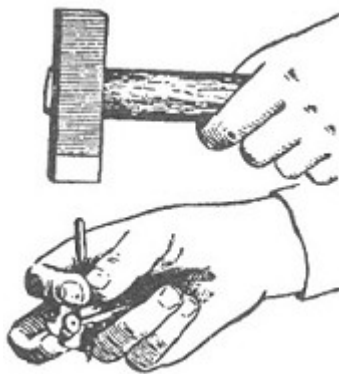

The bolt body has on the front faced- two cylindrical recesses for the case bottom and for the extractor; two locking lugs that engage in the receiver's locking recesses to lock the bolt; on top a guide lug for rotating the bolt during locking; on the left side a longitudinal slot for passage of the receiver's ejector lug (the slot widens at the end to facilitate the bolt's rotation during locking.) in the slimmer portion of the bolt body are holes for the extractor pin and firing pin retainer pin. The firing pin has a striker and a recess for the retaining pin. The extractor with spring extracts the case from the chamber and holds it until it encounters the receiver's ejector lug. The extractor has a claw for capture of the case, a pocket for the spring, and a notch for the pin. The retaining pin secures the firing pin.

Disassembly - With the drift or punch set, drive out the pin that retains the firing pin and extractor pin, and remove the extractor with spring from the bolt.

AK-47 Field Stripping

Like most firearms the AK-47 will start to show adverse wear and or malfunction if the weapon is not kept reasonably clean. Fortunately for the AK it is very easy to field strip, which makes cleaning not much of a chore. The AK requires no special maintenance tools or extensive knowledge of it's parts.

Materials:

- 1. Cleaning kit
- 2. News paper or throw-down

The Following Procedure should be used to field strip and clean the rifle.

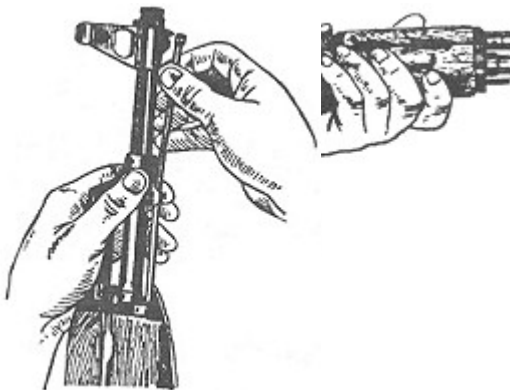

Removing the magazine Holding the rifle in the left hand at the upper hand guard and fore end, grasp the magazine with the right hand and remove it. The magazine is removed by pressing forward on the magazine catch. After this, ensure that there is no cartridge in the chamber by lowering the selector, pulling the bolt carrier handle to the rear, and inspecting the chamber. Release the bolt carrier handle and release the hammer from the sear (squeeze the trigger)

2) Remove the cleaning rod Pull the end of the cleaning rod away from the barrel so that its head is disengaged from the stop on the front sight base and pull the cleaning rod upward. The drift may be used when removing the cleaning rod.

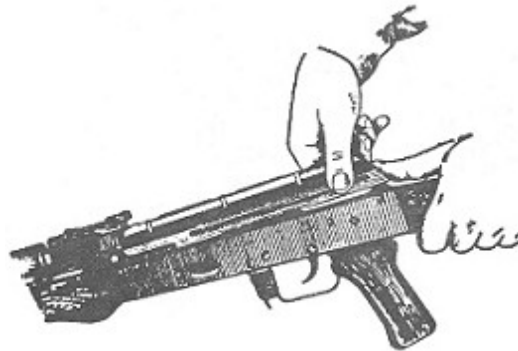

3) Remove the receiver cover Grasp the small of the stock with the left hand, and with the left thumb press on the recoil mechanism's guide rod lug. Lift the rear portion of the receiver cover upward with the right hand and remove the cover.

4) Remove the recoil mechanism. Holding the rifle in the left hand by the small of the stock, press the recoil mechanism's guide rod forward with the right hand until its heel emerges from the longitudinal slot of the receiver. Lift up the rear end of the guide rod and pull the recoil mechanism from the bolt carrier channel.



5) Remove the bolt carrier with bolt. Continuing to hold the rifle in the left hand, bring the bolt carrier to the rear to stop with the right hand. Lift it up along with the bolt and remove it

6) Remove the bolt from the carrier. Grasp the bolt carrier in the left hand with the bolt upward. Draw the bolt to the rear with the right hand, rotating it so that the bolt's guide lug comes out of the shaped slot of the bolt carrier, and remove the bolt forward.

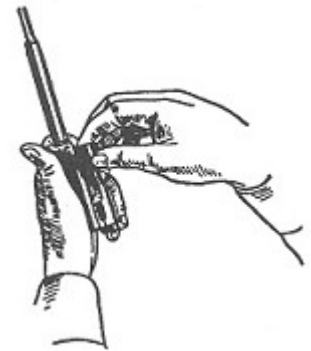

7) Remove the gas tube. Holding the rifle in the left hand, lift the gas tube latch located on the right side of the rear sight block. Rotate the small latch downwards and clockwise at the same time. This should enable you to free the gas tube, lift and remove it.

AK-47 Full Auto Trigger Group Disassembly

- a - hammer
- b - hammer spring
- c - trigger
- d - semi-auto fire sear
- e - auto sear
- f - auto sear spring
- g - selector
- h - pin
- I - semi-auto sear
- j - hammer retarder
- k - hammer retarded spring

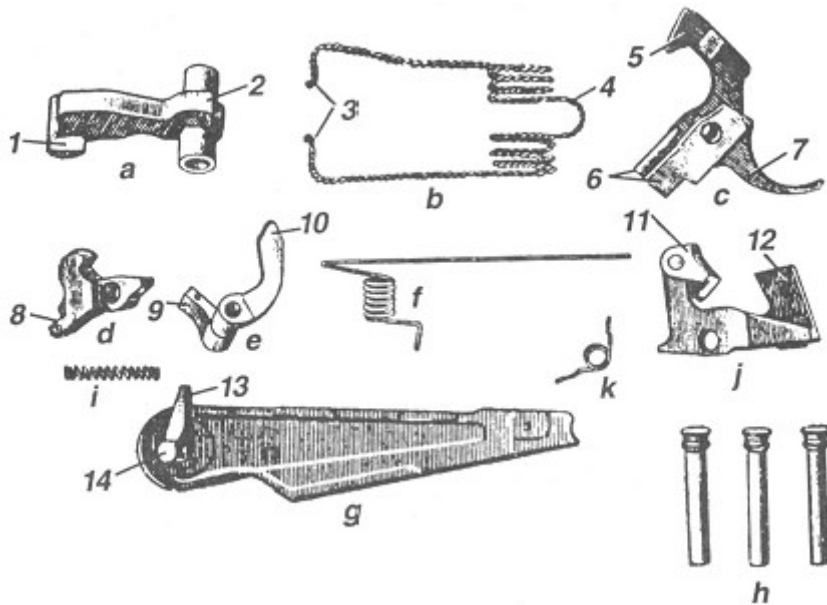

Disassembly of Full Auto trigger mechanism. - Holding the rifle with the left hand at the receiver, press on the auto sear and disengage the auto sear from the hammer with the right hand and using the drift. Release the hammer from the sear. Raise the left end of the hammer spring with the tapered end of the drift and guide it past the hammer's sear notch with the fingers. Guide the long end of the auto sear spring out of the circular channel of the trigger pin with the screwdriver. Tap the trigger pin to the left with the drift and remove it. Gradually pulling the drift out, extract the semi-automatic fire sear from the receiver along with its spring, spring retarder, and hammer retarder with the fingers of the left hand. Pressing back in the trigger piece with the left index finger, lift the trigger upward and remove it from the receiver with the right hand. Remove the hammer by pressing with the screwdriver on the long end of the auto sear spring, remove it from the circular channel of the hammer pin. Tap the hammer pin to the left with the drift. Holding the hammer with the right hand, remove the hammer pin with the left hand. Rotate the hammer so the left trunnion is toward the chamber and remove the hammer from the receiver. Remove the hammer spring from the hammer. Remove the auto sear. Tap the auto sear pin to the left with the drift and remove it. Remove the auto sear with spring through the magazine well. Remove the spring from the auto sear. Remove the selector by rotating the selector upward to the vertical position, move it to the right, and remove it from the receiver.

Handguard Disassembly

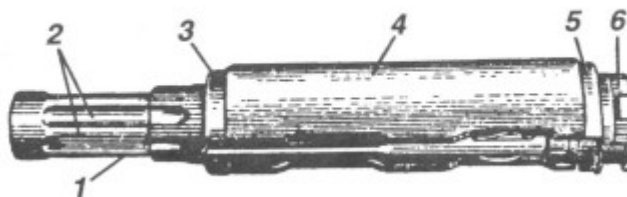

- 1 - Gas Tube
- 2 - Guide ribs for gas piston
- 3 - Front joining collar
- 4 - Hand Guard
- 5 - Rear joining collar
- 6 - Lug

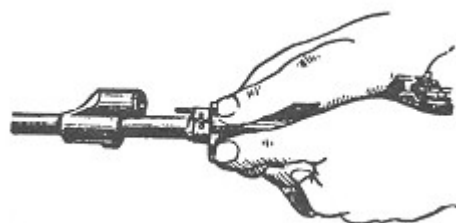

The gas tube directs the movement of the gas piston during shooting. It has guide ribs which direct the piston. The front end of the gas tube fits on the gas chamber. The hand guard protects the rifleman's hands from burns when firing. It has a channel in which it secures the metal semi-circular spacer that presses the hand guard away from the gas tube. The hand guard is secured on the gas tube by front and rear joining collars; the rear collar has a lug in which the gas tube lock engages.

Disassembly of the fore end - Grasp the rifle at the fore end in the left hand . With the right hand using a screwdriver rotate the fore end lock on half turn forward. Displace the connecting collar with fore end toward the gas chamber with the thumbs of both hands. Press forward on the fore end and remove it from the barrel.

AK-47 Magazine Disassembly

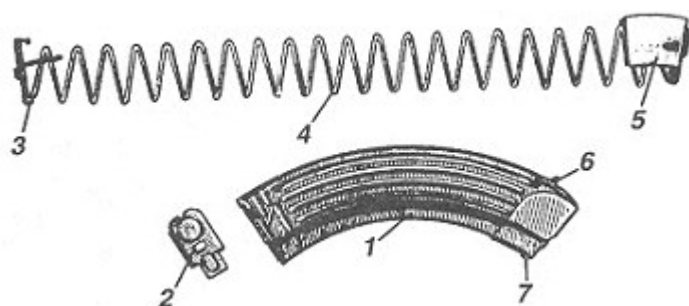

- 1 - Body
- 2 - Floor plate
- 3 - Stop leaf
- 4 - Spring
- 5 - Follower
- 6 - Stop Lug
- 7 - Catch

The magazine body joins all of the magazine's components together. Its lateral walls have lips to prevent the cartridges from falling out and lugs that limit the upward motion of the follower. On the front wall is the catch and on the rear wall stop lug, which together hold the

magazine in the receiver. On the bottom of the rear wall of the magazine's body is an inspection hold for determining if the magazine is fully loaded. The walls of the magazine are ribbed for strength. The bottom of the magazine is closed with a floor plate. The floor plate has a hole for the lug of the stop leaf. Inside the magazine body are a follower and spring with stop leaf. The follower is fastened to the upper end of the spring by an internal flange on the right wall of the follower. The follower has a lug that ensures the staggered positioning of the cartridges in the magazine. The stop leaf is permanently attached to the bottom end of the follower spring and holds the magazine floor plate from displacement with its lug. Some rifles have plastic magazines that are the same in construction as the metal magazines.

Disassembly Depress the small metal notch at the end of the magazine on the floor plate. Slide the floor plate backwards towards the rear or primer area of the magazine. Be careful the spring will shoot out with some force and could cause injury if not done slowly. Remove the spring and follower and the magazine is now disassembled. To reassemble just reverse the order of operation.

AK-47 Recoil Spring Disassembly

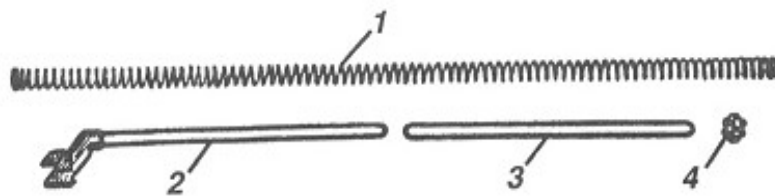

- 1 - Recoil Spring
- 2 - Guide rod
- 3 - Movable guide rod
- 4 - Collar

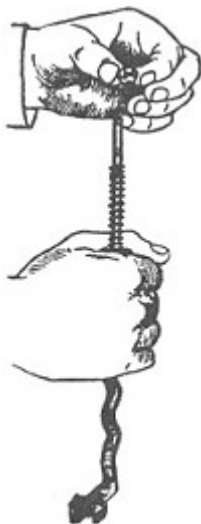

Disassembly Grasp the recoil mechanism in the left hand. Position the guide rod vertically with the heel down on the table or rest. Compress the recoil spring downward, and with the right hand separate the end of the movable rod and remove the collar. Remove the spring from the guide rod. Remove the movable rod from the guide.

AK-47 Troubleshooting

Below is a chart of potential items that may cause your rifle to fail. Next to it are the symptoms and fixes to correct the problem. Please read the chart carefully as it will make a difference.

<u>Problem</u>	<u>Check for</u>	<u>Procedure</u>
<ul style="list-style-type: none"> • Bolt wont Unlock 	<ol style="list-style-type: none"> 1. Dirty or burred bolt 2. Damaged Gas tube or piston 	<ol style="list-style-type: none"> 1. Clean or replace 2. Repair or replace
<ul style="list-style-type: none"> • Bolt wont Lock 	<ol style="list-style-type: none"> 1. Fouling in locking lugs 2. Frozen extractor 3. Recoil spring is not moving freely 4. Bolt is not moving freely. 5. Gas piston misaligned. 6. Loose or damaged piston. 7. Dent in gas tube 	<ol style="list-style-type: none"> 1. Clean & lubricate lugs. 2. Remove clean extractor. 3. Remove clean & lubricate. 4. Remove clean & lubricate. 5. Check alignment 6. Tighten or replace 7. Repair or replace
<ul style="list-style-type: none"> • Double feeding 	<ol style="list-style-type: none"> 1. Defective magazine. 	Replace
<ul style="list-style-type: none"> • Firearm wont cock selector doesn't work 	Worn, broken or missing parts.	Check parts, Replace
<ul style="list-style-type: none"> • Firearm continues to fire after re-release of trigger 	<ol style="list-style-type: none"> 1. Dirt in trigger/sear 2. Broken sear/trigger 3. Weak sear/trigger spring 4. Firing pin dirty or too long 	<ol style="list-style-type: none"> 1. Clean mechanism 2. Replace 3. Replace spring 4. Clean or replace
<ul style="list-style-type: none"> • Firearm wont fire 	<ol style="list-style-type: none"> 1. Safety in safe position 2. Firing pin is broken 3. Too much dirt/oil in firing pin recess 4. Poor ammo 5. Weak or broken hammer or spring 6. Weak or broken sear/sear spring 7. Bolt isn't locking 	<ol style="list-style-type: none"> 1. Place in fire position 3. Replace 4. Wipe/Clean 5. Remove/discard 6. Replace 7. Replace 8. Clean dirty parts
<ul style="list-style-type: none"> • Round won't chamber 	<ol style="list-style-type: none"> 1. Dirty or corroded ammo 2. Damaged ammo 3. Fouling in chamber 	<ol style="list-style-type: none"> 1. Clean ammo 2. Replace 3. Clean chamber
<ul style="list-style-type: none"> • Rounds won't eject 	<ol style="list-style-type: none"> 1. Broken ejector 2. Frozen ejector 3. Bad ejector spring 	<ol style="list-style-type: none"> 1. Replace 2. Clean/lubricate 3. Replace
<ul style="list-style-type: none"> • Rounds won't 	<ol style="list-style-type: none"> 1. Broken extractor or bad extractor 	

Spontanitto/JGAS